

How to use PC-logger AAC-2¹⁶ and accessories

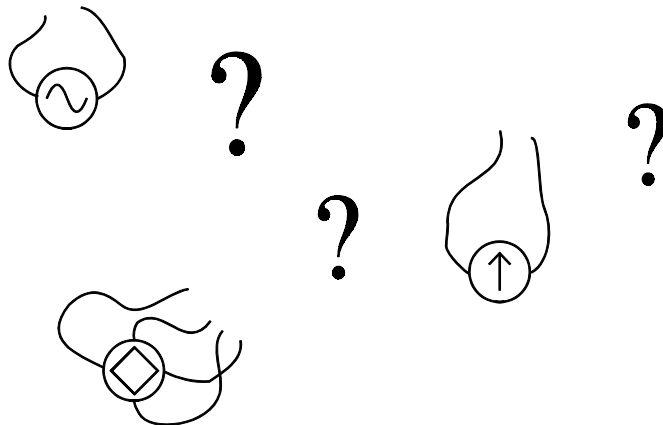
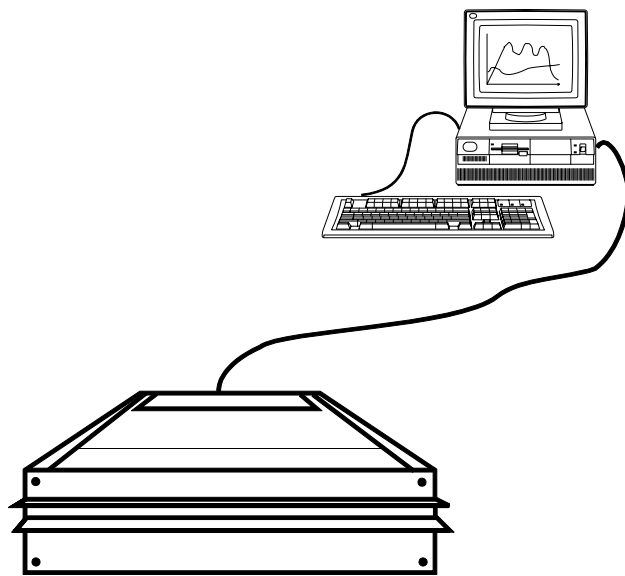

INTAB Interface-
Teknik AB

e-mail: info@intab.se

www.intab.se

CONTENTS

BASIC UNIT	5
1 AN OVERVIEW	5
1.1 General.....	5
1.2 "On-line" measurements	6
1.3 "Off-line" measurements	6
2 DISPLAY AND KEYS.....	7
2.1 CLOCK.....	7
3 STORAGE CAPACITY	8
3.1 Storage capacity in your computer	8
3.2 Storage capacity in the AAC-2	9
4 POWER SUPPLY	10
5 INPUTS - RANGES	11
5.1 Preset ranges.....	12
5.2 Software Switchable Ranges	12
5.3 RANGES AND THEIR RESOLUTION	13
5.4 Temperature measurements - T/C:s	13
6 CONNECTORS	16
6.1 Power	16
6.2 Computer.....	16
6.3 Connecting Sensors and Transducers	17
7 MISCELLANEOUS	23
7.1 Reset	23
7.2 Program	23
8 TECHNICAL SPECIFICATIONS	24
8.1 Analog Data	24
8.2 Storage Memory.....	26
8.3 Computer communication	26
8.4 Commands.....	26
8.5 Power	27
8.6 Mechanical specifications	27
8.7 Environmental conditions	27
OPTION: DIGITAL I/O AND PULSE COUNTERS.....	29
1 AN OVERVIEW	29
1.1 Digital Outputs.....	29
1.2 Digital Inputs	30
2 COUNTERS	31
2.1 Reset mode	31
2.2 Normal mode.....	31
3 CONNECTIONS	32
3.1 Digital outputs.....	33
3.2 Digital inputs.....	33
4 TECHNICAL DATA (@ 25C +/-10C)	35
4.1 Digital Outputs.....	35
4.2 Digital Inputs	35
4.3 Auxiliary Power	36

OPTION : CONSTANT CURRENT SOURCES.....	37
1 AN OVERVIEW	37
1.1 <i>Temperature Measurements with Pt-100 Sensors</i>	38
2 DESCRIPTION.....	39
3 CONNECTING SENSORS	39
3.1 <i>Screw Terminals</i>	39
3.2 <i>Measurement Methods</i>	41
4 TECHNICAL DATA	44
OPTION : MODEM PORT	45
1 DATA FORMAT	45
2 CONNECTOR STANDARD	45
3 AAC-2 MODEM SETTINGS.....	46
4 COMPUTER MODEM SETTINGS.....	47
INDEX.....	48

BASIC UNIT

1 AN OVERVIEW

1.1 General

The AAC-2¹⁶ (Analog to ASCII Converter) is the most popular of our "PC-loggers". It finds its use mostly in long term recording of process signals and/or temperatures. Common input ranges are +/-1V, +/-20mA or thermoelectric voltages.

Very high resolution (25 000 steps or divisions) and **excellent accuracy** (better than 400ppm) makes it possible to achieve remarkably good results from the most difficult measuring task.

An AAC-2 together with software and a personal computer constitutes a powerful data acquisition/recording system. It is an excellent and up to date substitute for strip chart recorders.

The rugged case lets you apply the AAC-2 in very harsh environments. Noteworthy are the rubber edges that spare your table tops.

The scope of this manual is to enable the user to correctly connect transducers and use the AAC-2 off-line.

How the AAC-2 is handled using our software and a PC is explained in the program manuals and by the programs themselves by their user-friendly and self-explanatory menus.

Those users who intend to write their own programs to collect data with the AAC-2 are recommended to study the special "Command manual" that describes available commands and their syntax.

In order to conserve battery capacity when the mains fail, the AAC-2 "falls asleep" when it hasn't been called upon for about 2 minutes. It is woken by incoming RS-232 serial data or by pressing the C key (see 2.).

Correct time is always supplied by our software.

On-line recordings are "timed" by the computer.

Transferring off-line parameters will also supply correct time to the logger RTC. Check your computer clock, should the recording time information be incorrect.

1.2 "On-line" measurements

On-line measurements are performed with the AAC-2 connected to the computer's RS-232 port. Measurements can in this mode be monitored in real-time on the computer's display. Incoming data are continuously transferred to disk.

1.3 "Off-line" measurements

Off-line measurements should be preceded by the transferral of measurement parameters from the computer to the AAC-2.

These parameters contain, among others (see program manual), information about time and date, measurement interval and which channels are to be active.

These parameters are effective until a new set is downloaded. The AAC-2 can, after downloading of the parameters, be disconnected from the computer and started with the help of the keys next to the LCD (see 2.).

After all measurements are completed the AAC-2 is again connected to a computer for transferral of collected data.

2 DISPLAY AND KEYS

The LCD (Liquid Crystal Display) with adjacent keys are supplied with all AAC-2 that are equipped with internal memory.

This display and key combination is indispensable when making off-line recordings. You indicate which function you want using the up/down arrows and then confirm your choice with the OK-key.

The MULTIMETER is used to check transducer connections and function before recording is started. You scroll up and down among the channels using the up/down arrow keys. Automatic scrolling is started with the key under the logo. A new channel is then shown every three seconds. Try this feature by pressing "AAC-2".

RECORD is selected when you intend to collect data. Verify your choice with "OK". See illustration below.

Starting a new recording will delete the previous one.

Don't forget to transfer data to the computer between recordings.

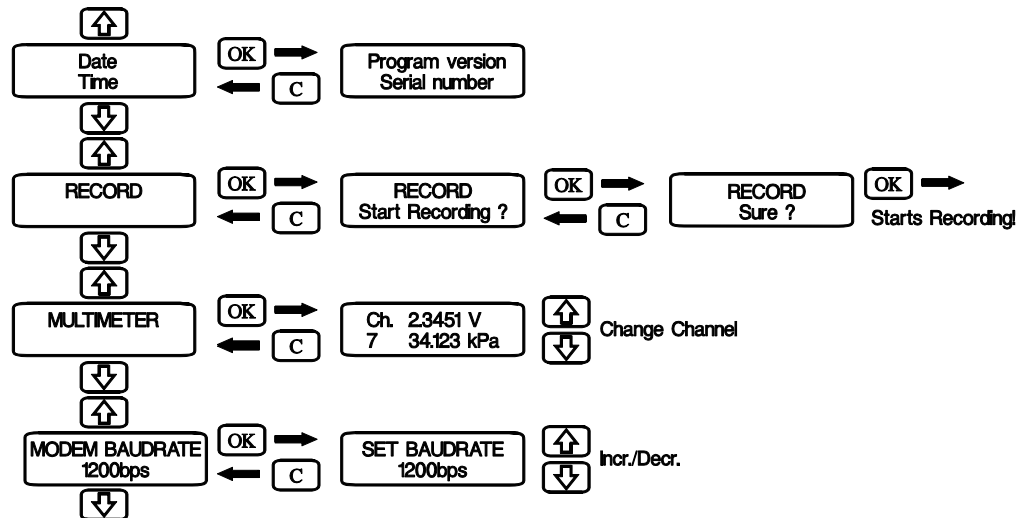

RECORD will also tell you "Recording on", if it is.

See Option: Modem Port for information on Modem Baudrate.

2.1 Clock

Logger time and date are shown in the display. They are set every time recording parameters are supplied by the software. Correct time and date are transferred from the computer together with off-line recording parameters.

The clock is only used by Off-line recordings. Start time and sampling interval (Δt) are used by the software to calculate data point time and date.

3 STORAGE CAPACITY

The number of measurements that can be stored by the AAC-2 and/or computer is dependent on the size and type of memory used.

The longest possible duration of a recording is a function of the number of channels that are active, sampling rate and the size of the storage medium.

A discussion of how the maximum length of a recording can be calculated from known parameters follows below.

It is assumed that recordings are made using software supplied by INTAB.

3.1 Storage capacity in your computer

The data storage capacity of your computer can easily be calculated.

The amount of free space on the disk that is to store your measurement data is the limiting factor.

Every measurement value saved, uses two of these locations or bytes.

A 3½” HD disk will store more than 1 440 000 bytes. This is sufficient to store a total of 700 000 values. As an example, this can be a sample of two channels every ten seconds for a total duration of more than 500 hours (i.e. more than 20 days).

Apply this to a hard disk, and you will find that storage space will last a very long time.

Remember that total storage time on a disk is the sum of all recordings. You just have to take into account that every recording takes about 16k of “header space”.

3.2 Storage capacity in the AAC-2

The storage capacity of the AAC-2 is dependent on memory size. Three sizes of memory can be supplied: 64k, 576k or 1088k. Every value stored uses two bytes, making it easy to calculate available recording time.

An example: having 64k memory you want to measure four channels 10 times every minute. The interval is then 6 seconds.

The formula will then be: $6 * 64\ 000 / 2 * 4 = 48\ 000$ seconds (or more than 13 hours).

The internal memory of the AAC-2 will only store **one recording at a time**. Starting a new recording will erase the previous one. Recordings have to be transferred to your computer before loading new parameters or starting new measurements.

There is no limit to the number of times the same recording can be transferred to the computer.

Measurement data will also not be lost if the internal batteries run down. A backup lithium battery will retain data for more than 10 years.

Rotating (or endless) memory is described in the program manual.

4 POWER SUPPLY

The AAC-2 is normally powered by the supplied mains adapter.

The AAC-2 is fitted with internal rechargeable batteries. They will give the user at least two hours of measuring time without mains supply. The batteries are trickle-charged when the mains adapter is connected.

There is no danger of overcharging the batteries, they **should** be left on charge to keep them ready to use at all times. This will also prolong the life of the batteries.

Completely discharged batteries may at first take up to about 15 minutes to charge to a point where the AAC-2 again will be operational. Two days of charging should be enough to bring them up to full capacity.

Some applications require the AAC-2 to be powered by other sources. Use a cable fitted with a TA3F (Switchcraft) connector to connect to, for example, a car battery.

Don't use sources supplying more than 15 Volts as this is the maximum allowed.

When the mains fails or is disconnected, the AAC-2 will "fall asleep" about two minutes after the last command or keystroke has been entered. This feature saves your rechargeable batteries for when they are needed.

Incoming serial (RS-232) commands or pressing the C-key will wake the AAC-2.

Recordings will of course proceed uninterrupted. Long sampling intervals will allow the logger to fall asleep between samplings thus conserving battery power.

5 INPUTS - RANGES

All analog channels are **DIFFERENTIAL**. They measure the voltage between - and GND and the voltage between + and GND. The subtraction is then performed internally.

NOTE

The GND is logger reference or signal ground. It has nothing in common with other system or safety grounds unless the operator interconnects them.

When we in the following pages refer to GND or ground we only mean the logger ground. **NOTHING ELSE!**

Standard inputs are balanced. This makes them very insensitive to noise if the signal source is correctly connected. A signal cable consisting of a twisted pair can be very long if the lowest potential of the source is connected to ground via a separate cable.

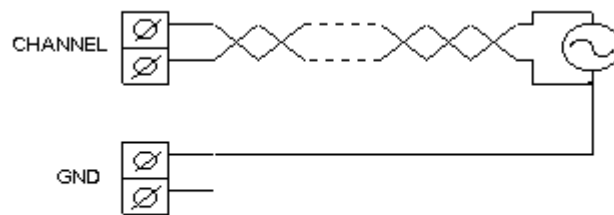

The input ranges are set, adjusted and calibrated at factory prior to shipment. Two main types of inputs are available: preset channels and "Software Range Switchable".

Preset channel units are individually "ranged", adjusted and calibrated, and cannot be altered by the user. They have to be returned to factory for modification.

AAC-2:s with Software Range Switching has four programmable ranges per channel. The range (or Full Scale Reading) of each channel is selected, or programmed, together with the rest of the "parameters" before the recording is started.

5.1 Preset ranges

The channels of AAC-2:s are in groups of eight.

The channels in such a group may be individually set to one of the available ranges.

Available ranges are +/-10V, +/-1000mV, +/-100mV, +/-50mV, 20mA and thermo emf:s.

Temperature inputs measure thermoelectric voltages. These are then cold junction compensated and linearized to present a correct value. All temperature channels are presumed to have the same type of T/C connected. AAC-2 has, as standard, linearization tables for types B, E, J, K, R, S, T, and N.

Other tables can be supplied on request.

All inputs (channels) have at least 25000 divisions. A division is the smallest discernible change in input signal. The resolution of an input can be expressed as FSR divided by the no. of divisions. Two examples:

a) A 10V input has a resolution of $10\text{V}/25000 = \text{ca } 0.4\text{mV}$.

b) A 50mV input has a resolution of $50\text{mV}/25000 = \text{ca } 2\mu\text{V}$.

5.2 Software Switchable Ranges

The AAC-2 can, as an option, be fitted with software switchable input ranges. This versatile option can be compared to the switch on an ordinary multimeter with the difference that the user has to press a number of keys on the computer instead of the meter.

Channels are individually programmable. T/C linearization is individually selectable so that channels may even have different types of thermocouples connected.

5.3 Ranges and their Resolution

An AAC-2 is especially suited for monitoring process type signals and still has the very sensitive 50mV range available.

The ranges and their resolutions are:

RANGE	RESOLUTION
+/- 10V	0.4 mV
+/- 1000mV	40 μ V
+/- 100mV	4 μ V
+/- 50mV	2 μ V

An input set to the 50mV range can measure temperature with a resolution of 0.1°C using T/C:s type K. The temperature range will in this case be -100 to +1200 °C.

Each channel has a shunt resistor that is connected across the input via a switch on the analog board adjacent to the screw terminals. This resistor has to be switched in manually when **current measurements** are to be taken (see 6.3.2.).

Range here is **0 - 20mA** which **resolves the signal to 6 μ A**.

Note that **4 - 20mA** signals are beautifully transformed into correct magnitude and unit by the "transform" function of the **software**.

NOTE that the shunt resistor will overheat if subjected to more than 80mA.

5.4 Temperature measurements - T/C:s

The AAC-2 is specially adapted for temperature measuring using thermocouples.

Thermocouples are active sensors that don't require powering to supply a signal. They are highly non-linear but are linearized by the AAC-2.

A thermocouple is in its simplest form a pair of wires of dissimilar materials that are soldered together at one end. The other end is connected to the two screw terminals of a channel. The difference in temperature between the soldered end and the screw terminals gives rise to a voltage that can be measured.

This voltage is different for different thermocouple materials so tell the software which type(s) you are using.

5.4.1 Ranges and linearization

Different types of thermocouples have differing levels of output. They therefore have differing fields of application most often depending on the temperature range to be measured.

What two materials make up the couple may also be of a certain importance.

We will however, have to assume that this is known to the user.

Below is a short summary of the properties of the most common types of thermocouples. It is included to help in selecting type and range for your application.

”K” is the most common type.

”Cold Junction” = 0°C

TYPE	mV at 200°C	mV at 600°C	mV at 1200°C	MAX temp °C
K	8.137	24.902	48.828	1370
N	5.912	20.609	43.836	1300
J	10.777	33.096	-----	760
T	9.286	-----	-----	400
S	1.440	5.237	11.947	1760
R	1.468	5.582	13.224	1760

Thermocouples are highly non-linear. This is corrected by the internal program of the AAC-2.

Thermoelectric voltage is measured (in mV) and then adjusted for the cold junction temperature according to the type specified. This adjusted voltage is then used as input variable to a linearizing table. The table (one for each thermocouple type) is constructed so that its contribution to the measurement error is negligible.

5.4.2 Cold Junction Compensation

When using thermocouples to measure temperature it is almost always necessary to know the temperature of the "cold junction". Thermoelectric voltage has to be "adjusted" with respect to this temperature.

Thermoelectric voltage is the result of the **temperature difference** between the cold junction and the hot junction.

A solid state temperature sensor has been placed centrally in the screw terminal area of the analog board. Its temperature is automatically sampled every time a temperature measurement is taken. All temperature measurements are thus compensated for the actual temperature of the terminals themselves.

Some precautions have to be taken if the AAC-2 is exposed to rapid temperature gradients. Since temperature is measured in one point only, a gradient from one side of the unit to the other may cause misreadings.

By giving the unit time to reach a stable temperature before recordings are started and by protecting it from sudden changes of ambient temperature a very high degree of accuracy can be achieved.

6 CONNECTORS

6.1 Power

Power is applied through a TA3F (Switchcraft) female connector connected as follows :

Pin	1 :	+ 12-15VDC
	2 :	0V
	3 :	+ 20-28VDC (this is an alternative to pin 1)

6.2 Computer

AAC-2 connects to a serial port of the computer using the supplied spiral cable.

The 15 pin D-SUB connector has the following pinouts:

pin 2 : Tx
pin 3 : Rx
pin 5 : CTS
pin 6 : DTR
pin 7 : GND

Leave the rest of the pins unconnected or damage may result!!

Typical Computer to AAC-2 cables:

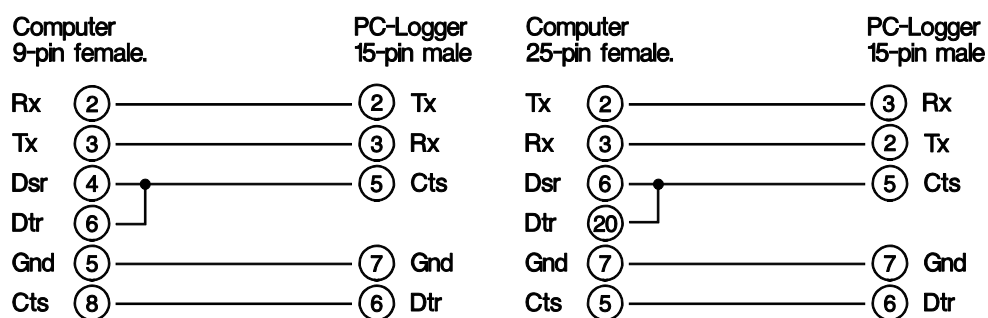

6.3 Connecting Sensors and Transducers

Sensors or Transducers are connected to the screw terminals that are accessible under the lid.

The terminals are detachable and can be tilted 90°. Terminal assignment and polarity can be seen in the figure below.

Use the 16 hole bracket as strain-relief for transducer cables. You can use a tie-wrap or simply thread the wire trough two holes.

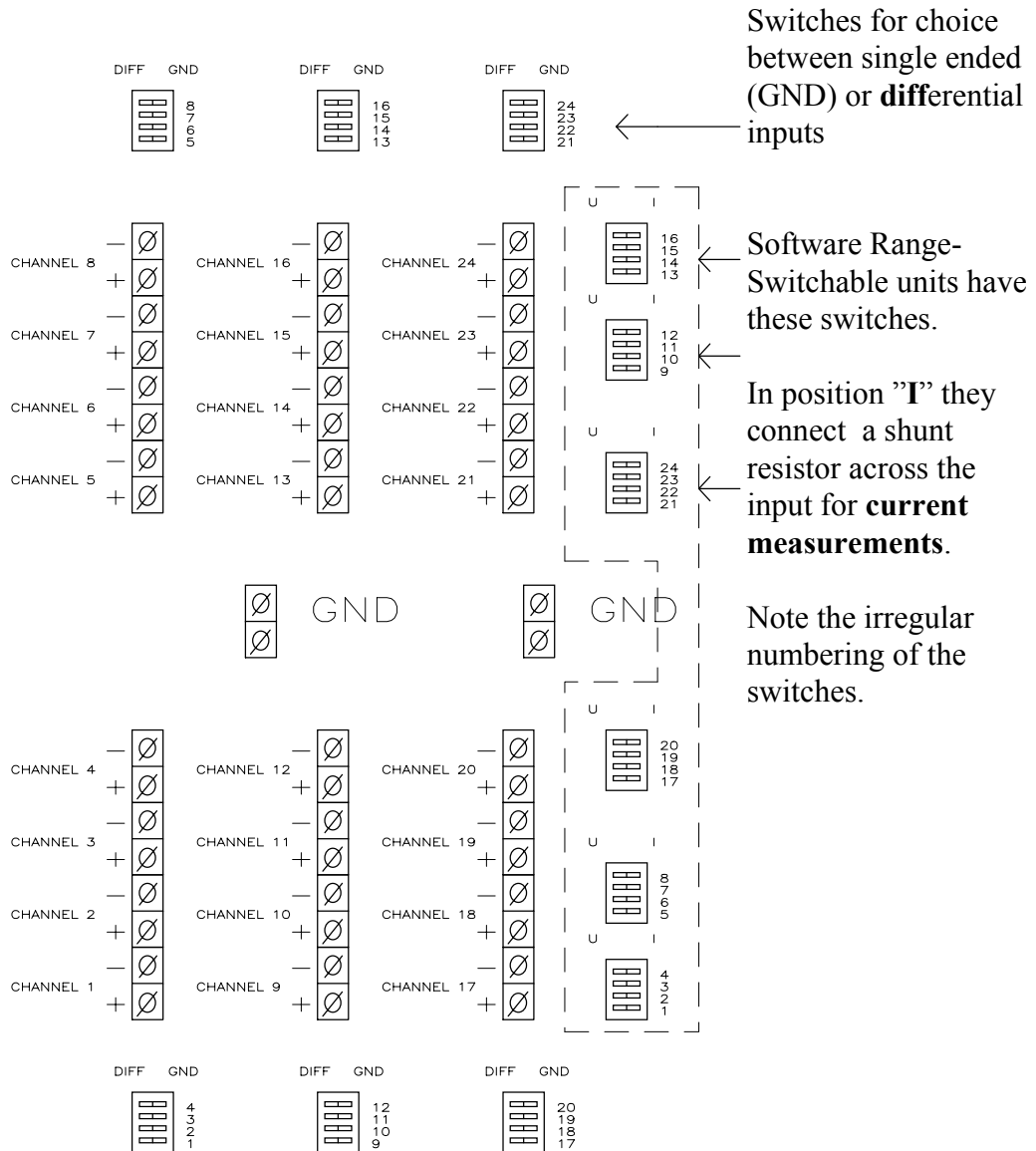

Connecting Sensors and Transducers (cont.)

The following information also applies to units fitted with jack panels. The panel is only an extension of the screw terminals. GND is also made available through two black banana jacks at the logger end.

There are a few basic rules that have to be followed when connecting sensors and transducers.

Let us first take a look at a block diagram of the inputs. They are **differential** and, as can be seen, have no internal connection to signal ground.

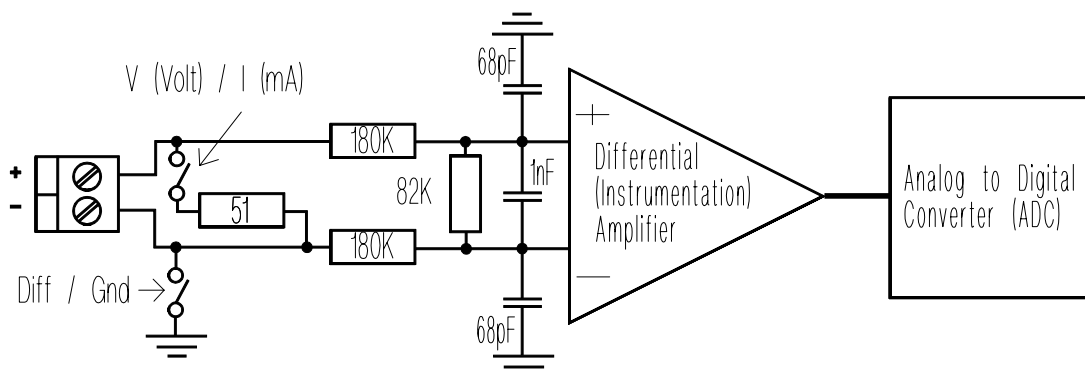

Input block diagram

Differential channels measure (as the name implies) the difference in voltage between the + and - input in relation to signal ground.

Another way of saying this is that **each channel measures TWO voltages:**

- a) between GND and minus and
- b) between GND and plus.
- The difference is then calculated internally and presented as the channel value.

By "GROUND" we mean the internal signal ground of the AAC-2. It has nothing to do with safety or system ground of other systems unless you interconnect them.

Also note that the AAC-2 analog ground is the same electrical point as the RS-232 signal return AND the 0V of the power supply input connector.

Connecting Sensors and Transducers (cont.).

The impedance between the positive and negative inputs to ground is of the order of several M Ω . They must therefore never be allowed to float outside the specified common mode range, but must be referenced to ground in some way.

Use the miniature switches to set up the channels as single ended inputs.

These switches ground the negative input of corresponding channels.

Before doing this, you have to make sure that no potential exists between the negative outputs of your transducers as this could burn out your wiring or worse.

You must also be careful not to introduce ground loops in your signal paths.

To maintain the validity of your measurements you have to take the common mode range into account.

Common mode range is +/-10V for most ranges.

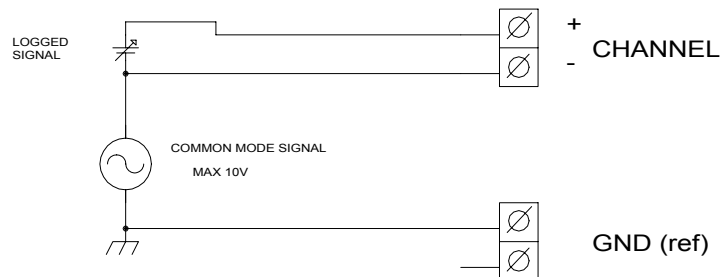

AAC-2 : "COMMON MODE"

The inputs will not be damaged by voltages above this as long as they are within 30V off signal ground.

The following sections of this manual will provide some examples of how transducers can be connected.

NOTE that these instructions also are valid for units with **jack panels**. You have to open the lid to make those channels single ended that should be single ended.

AAC-2 signal ground is here also available as two black banana jacks on one of the sides of the casing.

The jack panel must be looked upon as a device external to the logger itself. It is built into the logger casing only for practical reasons.

6.3.1 Thermocouples

Thermocouples can be connected in two ways (see fig. below). Which one you choose will depend on your particular application. As a general rule it would appear to be more practical to connect the negative input to ground by setting the switch in the single-ended position. Never leave any transducers without some type of connection to ground.

The two methods can be combined but you have to make sure that your ground leads don't carry any current or connect to the same point from two directions. Ground leads that carry current will, at best, ruin your measurements. At worst it will burn out your wiring.

Avoid these problems by using a one-point grounding scheme.

1) T/C "hot" junction in contact with measured object.

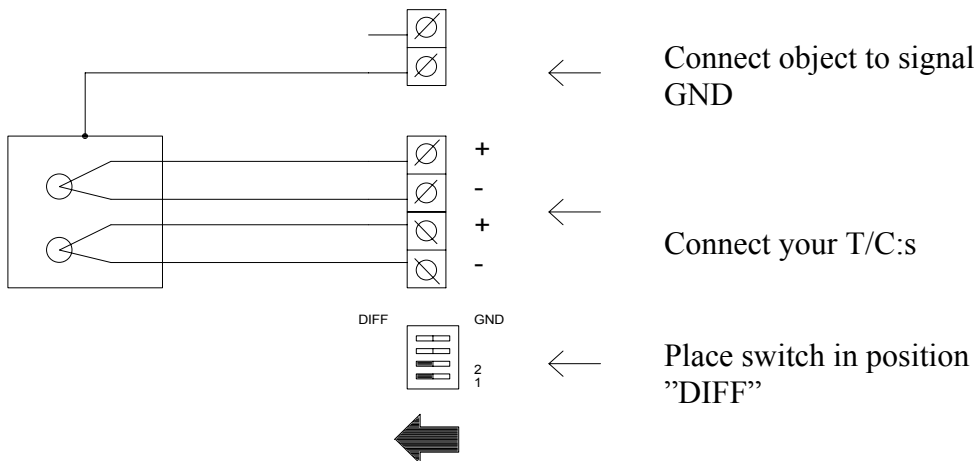

2) T/C "hot" junction isolated from measured object.

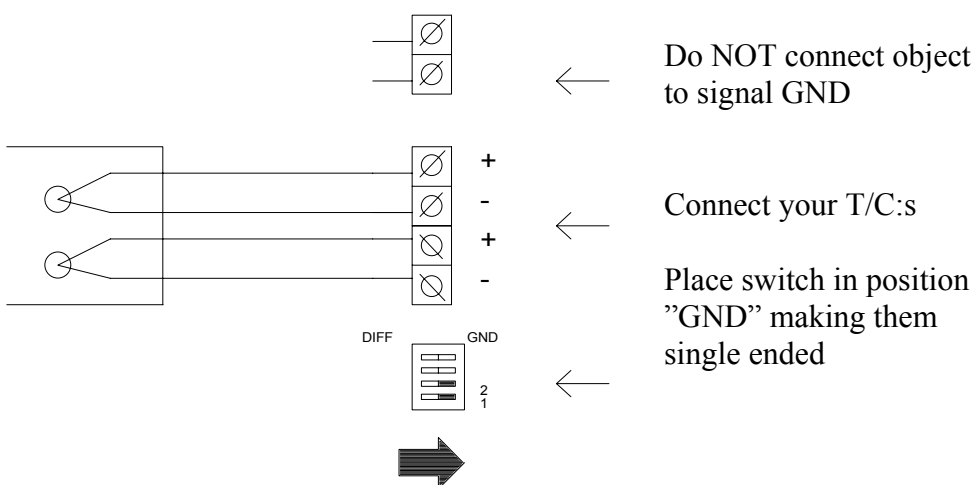

6.3.2 Current Loops

Current loops are usually process type signals (0 - 20mA).

The transmitters that output this type of signal are usually "floating" and don't present any problem in so far as grounding is concerned. Problems can, however, arise because other equipment that receives this signal may or may not be grounded.

Care must also be taken so that other equipment don't introduce common modes outside the permitted range. Least problems should arise if the AAC-2 is inserted as near the most negative end of the loop as possible.

1) "Grounded" current loops.

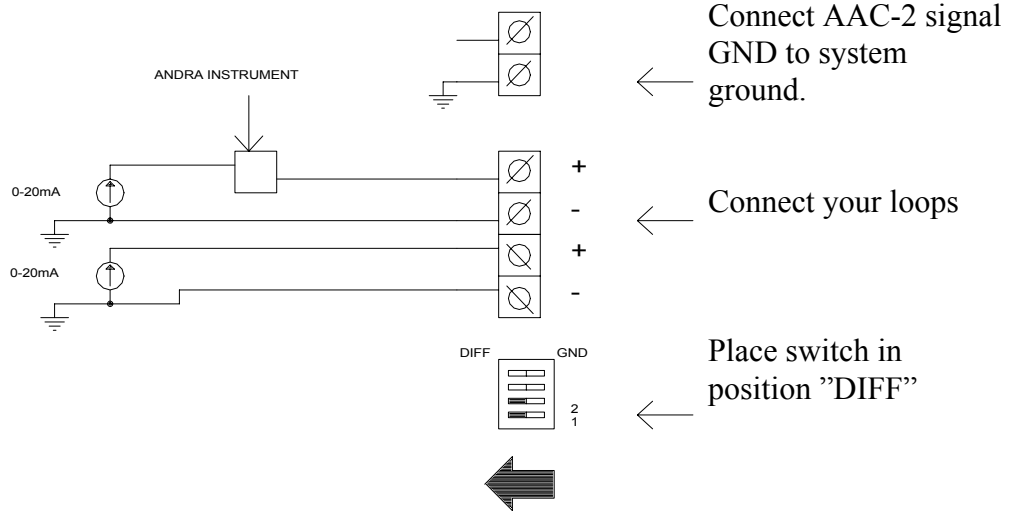

2) "Floating" current loops.

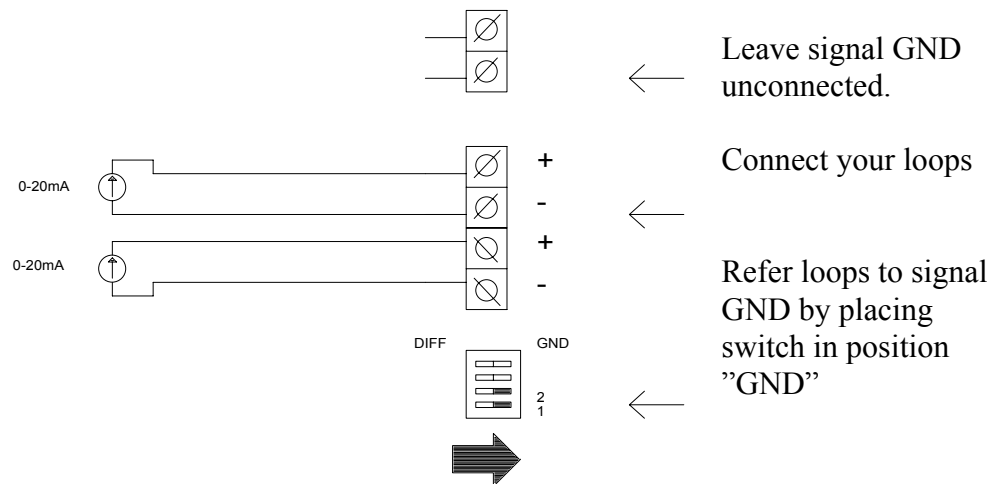

6.3.3 Voltages

Voltages are measured by connecting in one of the two indicated ways (see figure below). The two methods can be combined if care is taken to avoid ground loops.

1) Signals with Common ground reference.

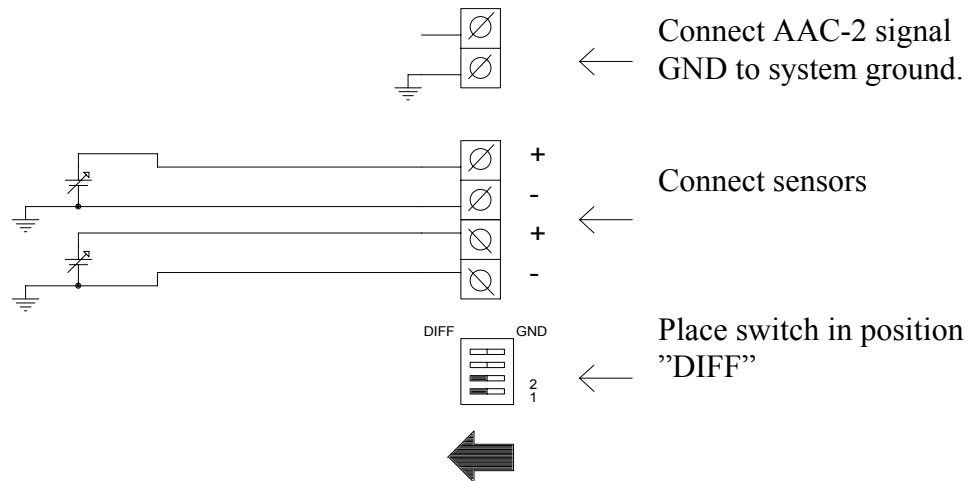

2) "Floating" signals.

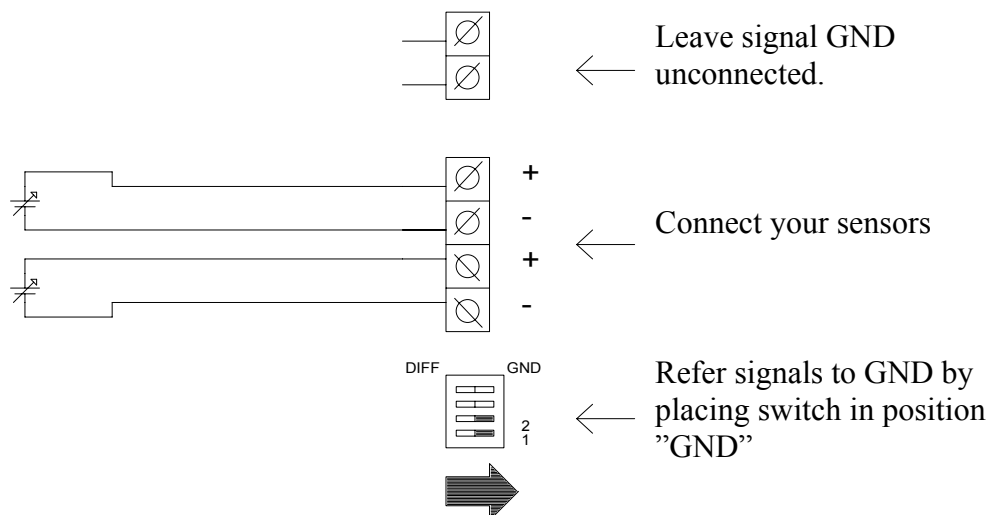

7 MISCELLANEOUS

As is implied by the topic, this section is intended for information that is not readily covered by the other sections of this manual. The information is, however, considered important or interesting enough to be included.

7.1 Reset

A master reset of the AAC-2 can be performed by temporarily shorting pins 7 and 8 of the 15 pin D-SUB connector. A master reset will erase the internal program of the AAC-2.

You will then have to re-boot the program from your computer. Rebooting is done from PC-logger software. Consult your software manual for details.

Bootable files have the extension .LDM. The PC-logger software automatically selects the correct one if there are several present on the disk.

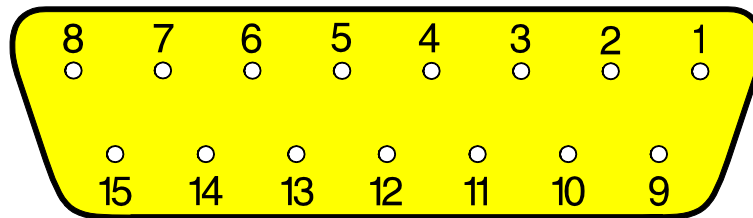

Front view of the D-SUB connector

7.2 Program

The program that controls the AAC-2 is stored in Random Access Memories in the AAC-2 itself. This makes it possible to modify the way the AAC-2 operates by simply downloading (or booting) a new controller program (see 7.1).

Bootable files reside on the same directory as your PC-logger software. They are recognised by the .LDM extension. These **Load Modules** are different for different models of loggers. Your software will always select the one appropriate for your logger.

8 TECHNICAL SPECIFICATIONS

8.1 Analog Data

8.1.1 Method

Σ - Δ converter

8.1.2 Measurement interval

Programmable in 1s steps - min 1s

N.B. : All channels are measured within the same second

8.1.3 Time Base

X-tal reference

Uncertainty 20ppm at 20°C

Stability 50ppm (-20°C to +60°C)

8.1.4 Inputs

8,16 or 24 **differential** inputs.

Impedance: Min 400 k Ω .

Overvoltage protection: 30V continuous.

Higher voltages may damage the inputs

N.B.: current inputs are shunted by 51 Ω

8.1.5 Ranges

Preset: 0-20mA, +/-10V, +/-1000mV, +/-100mV **or** +/-50 mV
Temperatures: 50mV thermo emf
Thermoelectric voltages are linearized and cold junction compensated

Switchable: Four Voltage Ranges per Channel
+/- 10V
+/- 1000mV
+/- 100mV
+/- 50 mV

One Current Range
0 - 20 mA

Each channel has a switchable 51Ω shunt for the 20mA range. It is connected across the input by using the on-board switch (see 5.2).

NOTE: Max. allowed current through shunt is 80mA

8.1.6 Divisions

Min 25000 divisions

8.1.7 Resolution

(Examples)

Range	Resolution (approx.)
10V	0.4mV
1000mV	40μV
100mV	4μV
50mV	2μV
20mA	800nA

Thermoelectric voltage, 50mV FSR: (Examples)

Thermocouple J	:	0.1°C
Thermocouple K	:	0.1°C
Thermocouple T	:	0.1°C
Thermocouple S	:	0.3°C
Thermocouple E	:	0.1°C

8.1.8 Uncertainty

(at 23°C +/-5°C)

	Ranges	(ppm of reading + divs.)
Voltage	10V	: +/- (100ppm+2divs.)
	1000mV	: +/- (200ppm+2divs.)
	100mV	: +/- (300ppm+2divs.)
	50mV	: +/- (400ppm+2divs.)
	20mA	: +/- (300ppm+2divs.)
Current		
Noise		+/-1 bit
Temp. co.		50ppm/°C
T/C linearization error		+/-0.1°C
Cold Junction		+/-0.5°C

8.1.9 Common Mode

Common mode range:	: min +/-5V at 10V FSR
	: min +/-10V other ranges
CMR	: min 80dB

8.2 Storage Memory

Sizes :	0k Bytes	(only for on-line recordings)
	64k Bytes	(optional)
	64k +512k Bytes	(optional)
	64k + 1024k Bytes	(optional)

8.3 Computer communication

Data is transferred in a serial form to and from the computer.

The serial standard conforms to a subset of RS-232.

Format:	8 bit ASCII
	1 start bit
	8 data bits
	1 stop bit
	19200 baud

8.4 Commands

See "Command Manual"

8.5 Power

Voltage:	12 - 15 VDC
Operating current:	Max 400 mA (charging + operating)
Charging current:	Max 200 mA (initial) Max 60 mA (trickle)

8.5.1 Rechargeable Batteries

Charging time:	Min 40 hours with supplied mains adapter. Should be continuously (trickle-)charged.
Capacity:	Min 2 hours of operation with fully charged accumulators

8.5.2 Charger/Mains Adapter

Voltage:	12 - 15VDC
Current:	Min 500 mA

8.6 Mechanical specifications

Width:	165mm
Length:	315mm
Height:	62 or 88mm (depending on model)
Weigh:	1.7 - 2.5kg (depending on model)

8.7 Environmental conditions

Min operating temp	-20°C
Max operating temp	+50°C
Min storage temp	-30°C
Max storage temp	+55°C
Max rel. humidity	80% non-condensing

OPTION: Digital I/O and Pulse Counters

1 AN OVERVIEW

The AAC-2 can, in addition to the analog inputs, be fitted with a digital I/O-interface.

This digital board is mainly used in event-counting applications but can also be used where status or on/off signals must be detected.

INTAB PC-logger software support the use of the relay outputs as alarms.

This card is available in two versions: with or without counters.

A fully equipped card has the following I/O's:

- 4 digital outputs (relays)
- 8 digital inputs, 6 of which are used as inputs to the counters.

1.1 Digital Outputs

Four digital outputs in the form of (relay) contact closures are available. They find their use as alarms and in simple regulating functions and are as such supported by the "GL" version of the software.

The relay coils are, to prolong battery life, powered directly by the mains adapter and not by the internal batteries.

The "GL" and EasyView PC-logger software support programming of alarm levels that can be assigned to these relays.

<p>Digital output status is reflected in channel 32. The binary sum of active outputs are presented with DO1 as LSB.</p>
--

1.2 Digital Inputs

Eight digital inputs are available. Input status of these can be monitored by the computer.

This way you can measure temperature and at the same time make sure that control signals assume the correct level at the right time.

Six event counters can be paralleled with these inputs.

By connecting pulse type transducers (flowmeters are often of this type) to these inputs you will get values that represent pulses/time interval. This is the easily transformed into litres per second.

The AAC-2 software can be said to be treating these values as if they were ordinary analog values or voltages.

The digital inputs are on request fitted with filters for electrically noisy environments.

**Digital input status is reflected in channel 31.
The binary sum of active inputs are presented with DI1 as LSB.**

1.2.1 Opto isolated inputs

The Opto isolated inputs (DI1 - DI8) are used to detect high-level (>10V) signals or where isolation is essential.

The a and b inputs are equivalent and insensitive to reversal of polarity.

The auxiliary output (VO) will power the opto-couplers if no external source is available. This output is connected directly to the mains adapter. Make sure you have connected it if you want to use this output.

Remember also that you lose isolation when you use VO.

1.2.2 TTL-compatible inputs.

TTL- or low-level signals are connected to the so called pulse inputs (P1-P6). These are paralleled with the corresponding DO inputs and do not provide any isolation to the measured/monitored object.

The auxiliary power output for these inputs is V_p .

This voltage is derived from the internal battery through a current limiting resistor

2 COUNTERS

The digital I/O card can be fitted with six sixteen bit counters. Each of these counts up to 65535 and then wraps around to zero.

They can be read with constant time intervals resulting in measurements values representing pulses per delta-t.

Flowmeters output a set number of pulses per given unit of volume. They are therefore an excellent example of how the counters can be used to measure flow.

Counter values are presented in channels 25 through 30

2.1 Reset mode

Reset mode will reset (or zero) the counters as soon as their values are taken care of. These values are then treated as if they were ordinary analog measurements. (Litres/second maybe?)

2.2 Normal mode

Normal (or accumulating) mode does not reset the counters when they have been read. Values that are taken with this mode are in fact the time-integral of the transducer output.

3 CONNECTIONS

Connections are made to the screw terminals under the lid of the AAC-2. Note that Vo is **un-fused** and should not be loaded by more than the mains adapter is able to supply and **never more than 500mA**.

Terminal configuration is shown in the illustration below.

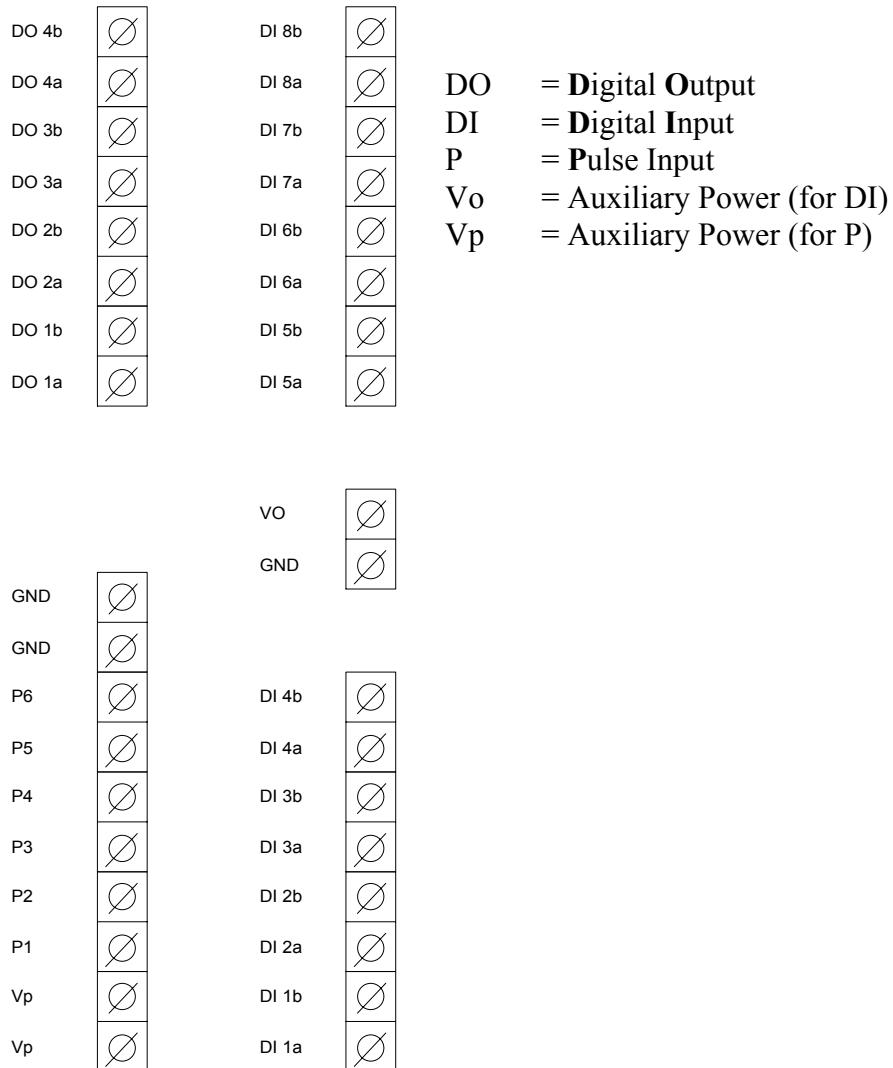

3.1 Digital outputs

The digital outputs are in the form of four normally open relays. These potential free contacts are accessible on DO1a,b - DO4a,b; see figure.

DIGITAL OUTPUTS

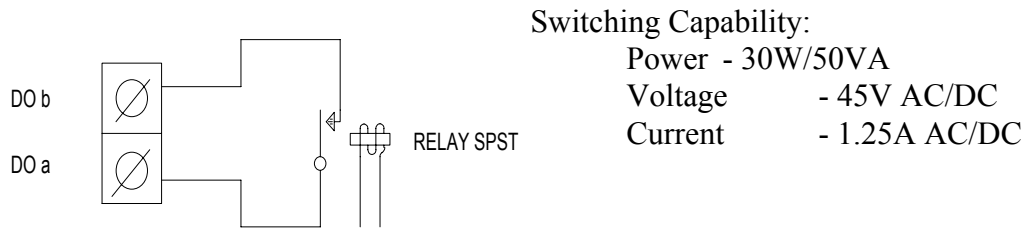

N.B. No voltage above 45V may be applied to any part of the logger.

3.2 Digital inputs

The figure below shows how the opto-isolated and TTL inputs are interconnected.

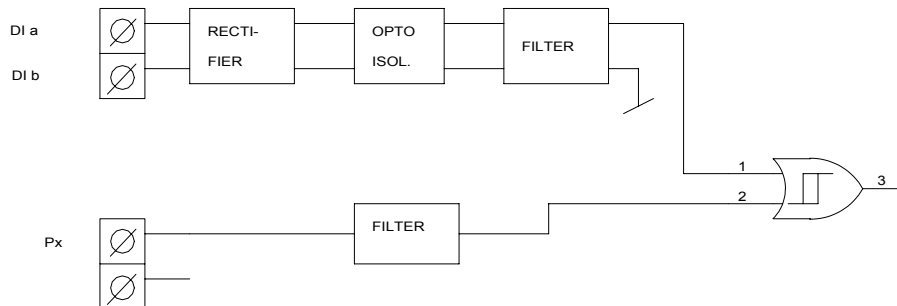

3.2.1 Opto Isolated

The opto-isolated inputs can be used in two ways. Which method you use depends on your particular application.

See figure!

The transducer marked "PULSE" has to be able to drive the input: see 4.2.1 for levels and frequencies.

Remember that mechanical **contacts** always **bounce** when brought together. This bouncing will, unless filtered, result in a burst rather than one pulse.



3.2.2 TTL Compatible

The TTL-compatible inputs (P = Pulse in) are connected as in the figure. Note that signal ground (GND) of the digital card has to be connected to signal ground of the system or transducer that is used with these inputs.

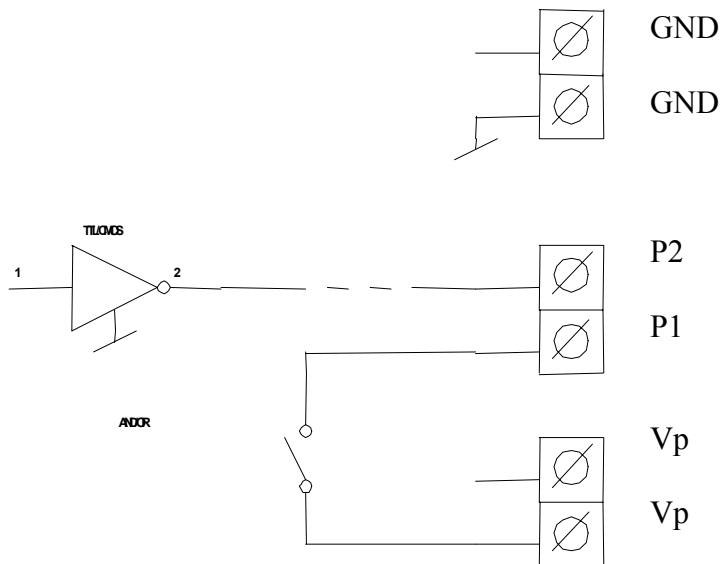

4 TECHNICAL DATA (@ 25C +/-10C)

4.1 Digital Outputs

No of outputs	: 4
Type	: Potential-free relay contacts (NO, SPST)
Switching capability	:
Power	: 30W/50VA
Voltage	: 45V AC/DC
Current	: 1.25A AC/DC
Max. operating current	: 1A @ 60°C

4.2 Digital Inputs

4.2.1 Opto-Isolated Inputs

No of inputs	: 8
"Low" level	: Max 4V
"High" level	: Min 8V
Max input voltage	: 30V
Impedance	: Min 1k Ohms
Input current	: Max 30mA at 30V in
Max frequency	: Min 30kHz at duty cycle 50%

4.2.2 TTL-compatible inputs

No of inputs	: 6
"Low" level	: Max 1.5V
"High" level	: Min 3.5V
Max input voltage	: 20V
Impedance	: Min 50k Ohms
Input current	: Max 30mA at 30V in
Max frequency	: Min 70kHz at 5V and duty cycle=50%
	: Min 30kHz at 10V and duty cycle=50%
	: Min 20kHz at 15V and duty cycle=50%
Min pulse width	: Max 15µs

4.3 Auxiliary Power

4.3.1 for Opto-Couplers

Voltage : mains adapter output, max 15V.
Current : mains adapter rating -300mA or max 200mA

4.3.2 for TTL-Inputs

Voltage : 4-6V
Impedance : 1k Ω

OPTION : Constant Current Sources

1 AN OVERVIEW

Constant Current Sources have their natural use when measuring resistance. A resistor is in itself passive and does not lend itself to be measured unless special arrangements are made. It has to be tricked into revealing its value as a voltage that can be measured and logged.

This voltage has to be proportional to the resistance.

An excursion in time, back to the old school days, may make you remember "Ohm's Law". It states that $U=R*I$. I.e. "the voltage across a resistor is the product of the current through it and its resistance".

Juggle the letters a bit and you get $R=U/I$ (School maths again).

As current (I) is known and constant it is easily seen that measured voltage is directly proportional to resistance.

The constant current is almost always set to 0.500mA. I.e. every measured mV corresponds to 2Ω . Insert these values into the formula above and you get:

$$1\text{mV}/0.500\text{mA} =$$

$$10^{-3}/0.5 * 10^{-3} \text{ (V/A)} =$$

$$1/0.5 \text{ (V/A)} = 2\Omega \text{ (V/A}=\Omega)\text{! QED}$$

Below is a schematic diagram of how a constant current source can be put to work.

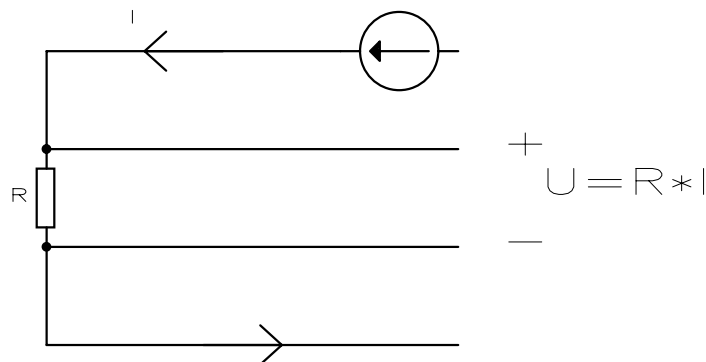

This method is called "four-wire resistance measurement".

How to do the practical wiring is shown in a later section in this manual.

1.1 Temperature Measurements with Pt-100 Sensors

A Pt-100 is a resistance temperature sensor or RTD (Resistance Temperature Detector). Its resistance changes with temperature. By measuring resistance using the four-wire technique described above, it is easily converted to temperature. The conversion can be either a linear transform ($y=kx+l$) or for more accurate conversions a polynomial.

One linear transformation can be defined as the line that passes through 0°C at 100Ω and f. ex. $266,4^{\circ}\text{C}$ at 200Ω . In other words: 50mV corresponds to 0°C and 100mV corresponds to 266.4°C
($I=0.5\text{mA}$)

If you want to transform resistance into temperature you can of course use this equation: $R_t=R_o(1+At+Bt^2)$
where $R_o \sim 100$
 $A \sim 3.9083 \times 10^{-3}$
 $B \sim -4.183 \times 10^{-7}$

Concerning accuracy of the AAC-2 when performing Pt-100 measurements, the following should be noted:

In four-wire techniques total uncertainty is the sum of AAC-2 analog channel uncertainty and constant current uncertainty. The analog inputs have an uncertainty of $\pm 300\text{ppm}$. Using the 100mV range and reading 50mV , this translates to about $15\mu\text{V}$. The constant current sources have an uncertainty of $\pm 0.5 \mu\text{A}$. At a resistance of 100Ω this corresponds to $100\Omega * 0.5 \mu\text{A} = 0.050 \text{ mV}$.

A Pt-100 sensor changes its resistance from 100.0Ω to 100.39Ω as a result of a temperature change from 0°C to 1°C .

As the constant current is 0.5mA this corresponds to:
 $0.39\Omega * 0.5\text{mA} = 0.195\text{mV}$. Therefore:

- uncertainty due to input is $0.015/0.195 = 0.08^{\circ}\text{C}$.
- uncertainty due to constant current is $0.050 / 0.195 = 0.26^{\circ}\text{C}$.

Total uncertainty can therefore, if you are unlucky, add up to 0.34°C . (AAC-2 @ $25^{\circ}\text{C} \pm 10^{\circ}\text{C}$)

Don't forget that Pt-100 sensors by no means are perfect.

A class B Pt-100 has an uncertainty of $\pm 0.8^{\circ}\text{C}$ at 100°C and

a class A Pt-100 has an uncertainty of $\pm 0.35^{\circ}\text{C}$ at 100°C .

These possible errors have to be added to the AAC-2 uncertainty to get a reliable estimate of total system uncertainty.

2 DESCRIPTION

Each constant current sources board may have 8, 16 or 24 constant current outputs.

Every group of 8 sources is really only one source that is multiplexed in turn to the eight outputs.

This means that the constant current is not flowing all the time. It is only present and constant during the time its associated channel is being sampled.

Each channel takes between 80ms and 100ms to sample. The maximum time the constant current is flowing is actually only this long. Therefore it never contributes to any self-heating of the sensor.

What are the implications of what we have just said? well!

Channels are sampled one by one within an 8-group.

As channel one is sampled there is a constant current coming out of source #1.

As channel two is sampled there is a constant current coming out of source #2.

And so on.

Note that channel groups 9-16 and 17-24 are "in step" with the first group. I.e. channel 9 and channel 17 are sampled concurrently with channel number one.

3 CONNECTING SENSORS

3.1 Screw Terminals

The screw terminals for the current sources are placed symmetrically with respect to corresponding analog channels. They are therefore easily and logically connected to sensors.

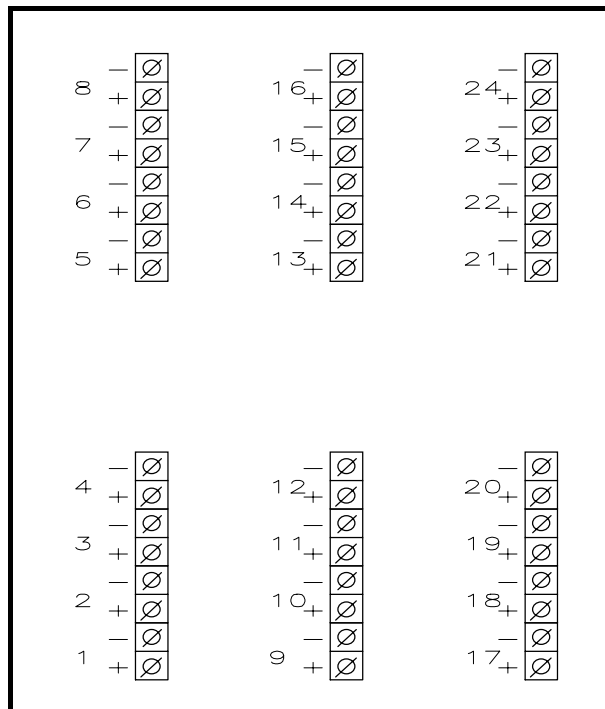

The constant current comes out of the "+"-terminal whenever the corresponding channel is sampled.

It should pass through the sensor resistance and return to the "-"-terminal. This minus terminal is in actual fact the AAC-2 reference ground or as it is usually called: GND.

The Diff/Gnd switch should be in the Diff position !!!! (Hopefully you had realised this already.)

3.2 Measurement Methods

There are several ways of connecting, and measuring the value of, resistive components. Here follow a few:

The **four-wire** resistance measurement method is the most straight forward and accurate method.

The **five-wire** method also has its place in some applications.

A **three-wire** version of the five-wire method can also be employed where the demand for accuracy is small.

Three-wire resistance measuring where the three-wire device is part of a Wheatstone **bridge** is also common. The resistance to be measured is one of the four resistances of the bridge. Should this method be preferred, the user can easily calculate the other three legs of the bridge. For more information please consult applicable school literature on this subject.

3.2.1 Four-Wire Resistance Measurements (Pt-100)

The theory behind this method is explained earlier in this manual.

Below is a schematic diagram of how to connect two Pt-100 sensors. It can of course be expanded to up to 24 sensors.

You realise, of course, that these can be combined with other sensors and transducers that don't require current sources.

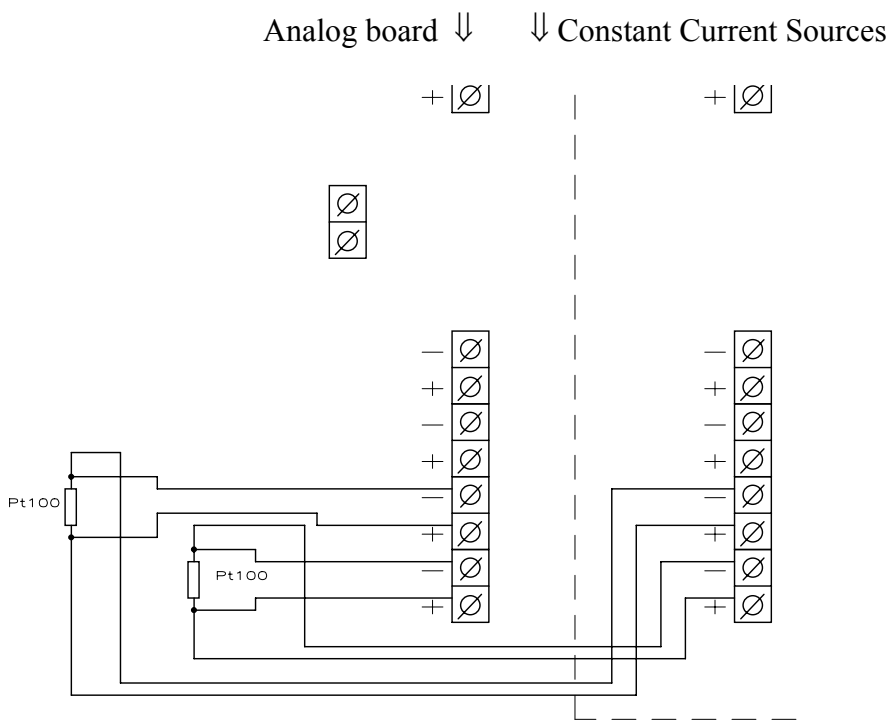

With this method all sensors are referenced to AAC-2 signal ground via the constant current return (-). The Diff/Gnd switch must consequently be in the Diff position (right?).

3.2.2 Five-Wire Resistance Measurements

This method is used when there is a requirement for a wider range than is possible using the four-wire technique when measuring temperature with an RTD (Pt-100).

By using the "differentiality" of the analog channels a base level resistance (like 100Ω of the Pt-100 at 0°C) can be subtracted.

This is how to do it shown in schematic form:

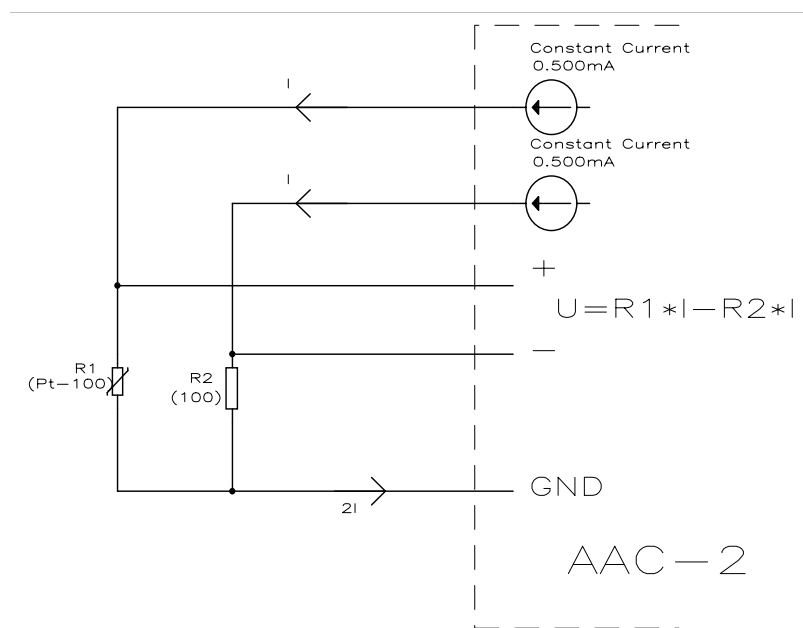

The plus input of the channel measures the voltage developed across the temperature sensor (R1).

The minus input measures the voltage developed by a similar current source across a reference resistor (R2).

The lead return resistance is with this method elegantly compensated for as it is included in both the minus and plus signal and thus subtracted from the sensor measurement.

How to calculate temperature from resultant voltages using different values for R2 is common high school mathematics and is left to the operator. We recommend the use of Pt-100 tables however.

Apply the best fit straight line (equation) transform to the temperature range that is to be recorded. This will give best and most accurate readings. A very good accuracy can be achieved if the constant current sources and the reference resistor are calibrated.

NOTE also that the two current sources needed for each sensor must be "in step". Use for example the pairs 1 and 9, or 2 and 10, or 3 and 11, and so on.

3.2.3 Three-Wire Resistance Measurements

This method is a poor version of the five-wire method. Its only excuse is that it only needs three wires to the sensor. (It must not be mistaken for the three-wire bridge method that is not dealt with in this manual). This method requires the lead resistances to be either compensated for by calibration or unimportant enough to be disregarded. They will otherwise contribute to a considerable measurement error.

This is how you go about connecting the three wires. Compare this to the five wire method!

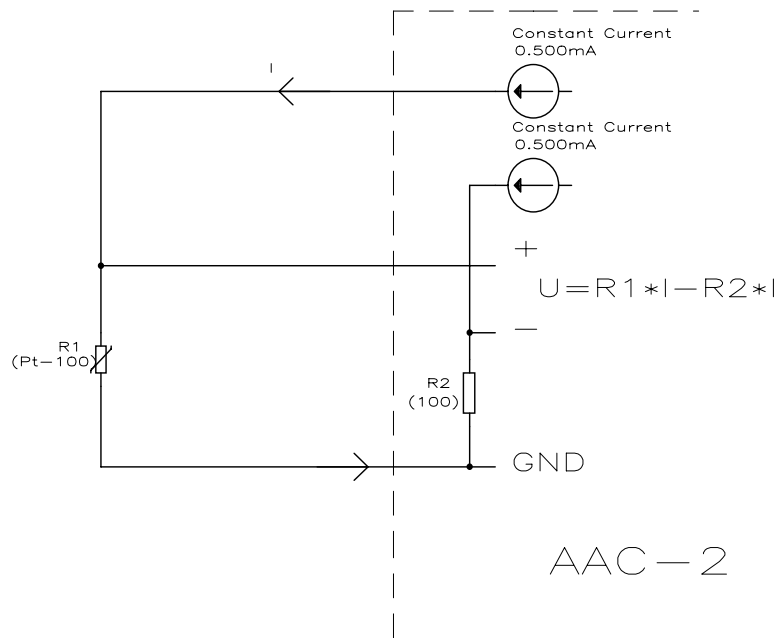

Use ordinary high school maths and Pt-100 tables to convert measured voltage into temperature. Apply the best fit straight line (equation) transform to the temperature range that is to be recorded. This will give best and most accurate readings.

4 TECHNICAL DATA

At 25°C and nominal current 500µA (other ranges on request)

Constant Current	500µA
Accuracy	+/-0.5µA
Compliance	2.5V (0≤RL≤5kΩ)
Tempco (max)	+/-150ppm/°C

OPTION : Modem Port

AAC-2:s may on demand be fitted with a modem port. This serial port is specially adapted to modems.

1 DATA FORMAT

The serial data format between the AAC-2 and a modem is:

1 Start Bit
8 Data Bits
1 Stop Bit
No Parity

2 CONNECTOR STANDARD

The connections adhere to a subset of the RS-232C standard.
The connector is 25 pole D-sub connected as a DTE connector.
The following pins and signals are used:

2) Tx
3) Rx
4) DTR
5) CTS
7) Signal Return
8) DCD
20) DTR
22) RI

3 AAC-2 MODEM SETTINGS

Press the up or down arrow by the AAC-2 display until you see the "MODEM BAUDRATE" menu. See basic unit manual chapter 2 !

Press OK to see the menu "SET BAUDRATE". Select desired baud rate using up or down arrow and end off by OK.ing. The menu should indicate selected baud rate under the caption "MODEM BAUDRATE".

There are four commands that set up the AAC-2 for modem control. See also the "Command Manual".

The command INITANSWER supplies the string that initialises the modem as the first ring signal arrives.

ANSWER will supply the string to be sent to the modem to make it answer the call. DIAL" supplies the commands that are to be performed at an alarm situation.

RING is a command that programs how many rings that must arrive before the call is answered.

The commands have the following default settings (BPA_0226.LDM or later):

INITANSWER	ATE0!
ANSWER	ATA!
RING	3
DIAL	Has no initial settings. Can be : ATZ!£ATE0!ATDT123456789! Consult the Command Manual for more information

To set these parameters the AAC-2 has to be connected to the computer serial port and some type of terminal software running.

The following commands are examples and may or may not suit your modem:

INITANSWER:"ATZ!£ATE0!£ATW2S95=2!"	AAC-2 responds with OK
ANSWER:"ATA!"	AAC-2 responds with OK

Settings can be checked by typing:

INITANSWER:?	AAC-2 responds with "ATZ!£ATE0!£AT&C0!"
ANSWER:?	AAC-2 responds with "AT&C1!£ATA!"

The exclamation mark "!" and pound sign "£" have special functions:

! :There is no normal way to include the [Enter] character in a string. The ! replaces it.

£ : Some MODEMS are not able to receive multiple commands without a break in between. The £ introduces a 2 second pause.

4 Computer MODEM settings

It is not always a trivial task to get modem communications to work. There are several parameters that have to be correctly set up. MODEMS do not necessarily have to be of the same type but it usually helps.

MODEMS of your choice have to be set up to report DCE line speed and error correction method. (xxx = arbitrary letters)

The following two types of messages are accepted:

- CONNECT 14400 No error correction
- CONNECT 14400/xxx Error correction

The highest speed with which the modems are able to operate is the RS-232 baud rate. Computer baud rate is set in the MODEM.INM file

If the logger modem answers CONNECT 14400/ARQ, the computer modem has to reply with an identical string. (And vice versa).

INDEX

A

accumulating · 31
alarm levels · 29
alarms · 29
ANSWER · 46
available ranges · 12

B

B · 12
backup · 9
balanced · 11
Boot · 23
bounce · 34
burn out · 20

C

clock · 5
Clock · 7
CMR · 26
cold junction · 15
cold junction temperature · 14
Common mode · 19
Compliance · 44
computer · 16
computer clock · 5
Constant Current · 44
Constant Current Sources · 37
controller program · 23
Correct time · 5
counters · 29, 31
Current loops · 21
current measurements · 13, 17

D

date · 7
detachable · 17
DIAL · 46
DIFF · 21, 22
differential · 18
DIFFERENTIAL · 11
digital I/O · 29
digital inputs · 30
digital outputs · 33
division · 12
downloading · 6
D-SUB · 16
DTE connector · 45
duration · 8

E

E · 12
endless · 9
erase · 23
error correction · 47
event-counting · 29

F

fall asleep · 10
five-wire · 41
flow · 31
four-wire · 41
four-wire resistance measurement · 37

G

GND · 11, 18, 21, 22
gradient · 15
ground · 20
GROUND · 18
ground loops · 22

H

hard disk · 8
HD disk · 8
hot junction · 15

I

impedance · 19
Impedance · 24
internal memory · 9

J

J · 12, 14
jack panels · 18, 19

K

K · 12, 13, 14
keys · 7

L

LCD · 7
LDM · 23
linear transform · 38
linearization tables · 12
linearized · 13
Load Modules · 23

M

mains adapter · 10

mains fails · 10
master reset · 23
miniature switches · 19
misreadings · 15
MODEM BAUDRATE · 46
modem control · 46
modem port · 45
multimeter · 12
MULTIMETER · 7

N

N · 12, 14
Normal mode · 31

O

Off-line · 6
Ohm's Law · 37
OK · 7
On-line · 6
Opto isolated inputs · 30
opto-isolated · 33, 34
overheat · 13
Overvoltage protection · 24

P

P · 34
pinouts · 16
Power · 16
preset channels · 11
process · 13
programmable · 12
Pt-100 · 38
PULSE · 34
pulse inputs · 30

R

R · 12, 14
ranges · 12
Rebooting · 23
rechargeable batteries · 10
RECORD · 7
recording time · 9
relay coils · 29
relay outputs · 29
Reset mode · 31
resistance · 37
resolution · 13

retain data · 9
RING · 46
RS-232 · 26
RTC · 5
RTD · 38

S

S · 12, 14
screw terminal · 15
screw terminals · 17
self-heating · 39
shunt resistor · 13, 17
single ended · 17, 20
single-ended · 20
Software Range Switchable · 11
storage capacity · 8, 9
strain-relief · 17
system ground · 18
system uncertainty · 38

T

T · 12, 14
T/C:s · 20
temperature · 13
temperature sensor · 15
Terminal configuration · 31
thermo emf · 12
thermocouples · 13, 14
Thermoelectric voltage · 15
three-wire · 41
time · 5
time and date · 7
transfer · 9
transferral · 6
trickle-charge · 10
TTL · 33
TTL-compatible · 34

U

$U=R*I$ · 37
uncertainty · 38

W

wake the AAC-2 · 10
Vo · 31
Voltages · 22